

Features

Features	Code
Brake Caliper	H
Standard	W
With piston diameter 63 mm	063
Hydraulically activated	H
Spring released	F
Automatic adjustment to counter friction block wear	A
Max. clamping force 28 kN	028

Example for ordering

Brake Caliper HW 063 HFA, max. clamping force 28 kN:

HW 063 HFA - 028

Technical Data

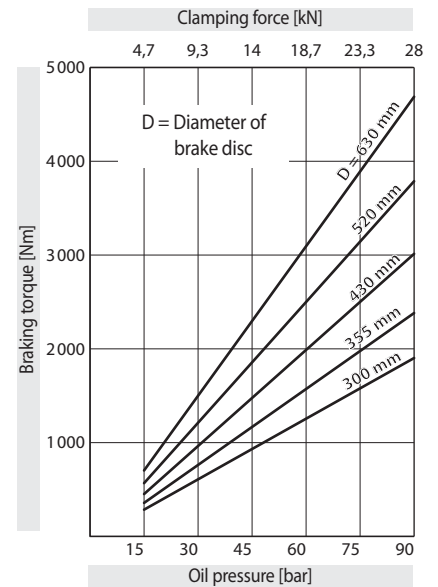

The braking torques shown in the diagram are based on a theoretical friction coefficient of 0,28.

Oil pressure: min. 5 bar
max. 90 bar

Oil volume: 20 cm³ per stroke

Weight: 8 kg

Other features

- The thickness of the customer connecting part results from the thickness of the brake disc W plus 3 mm

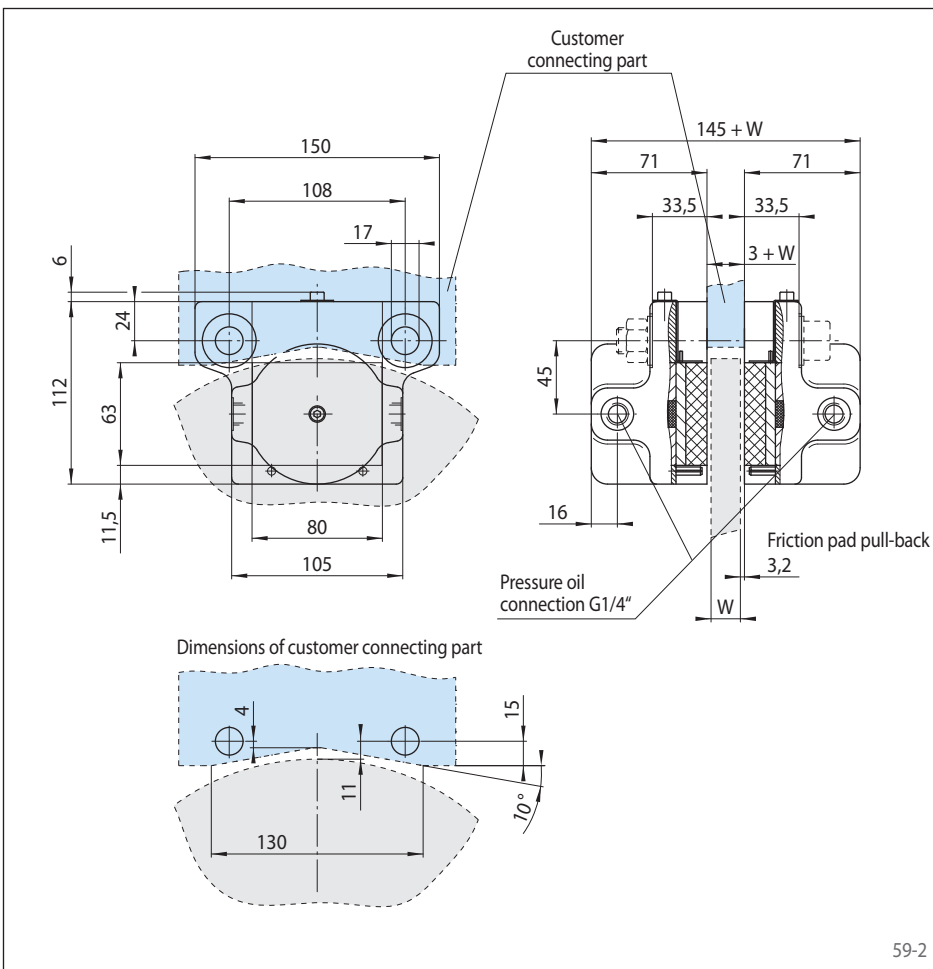

59-1

59-2